

650V 7A Insulated Gate Bipolar Transistors

FEATURES

- $V_{CES} = 650V$, $I_C = 7A$ ($T_C = 100^\circ C$).
- Trench Gate and Field Stop Processes IGBT .
- Low $V_{CE(sat)}$ and High Switching Speed .
- Positive $V_{CE(sat)}$ Temperature Coefficient .
- 10us of Short - circuit Withstand Time .
- Soft and Fast Recover Antiparallel Diode .

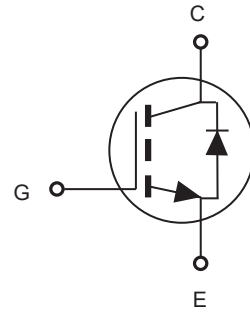

ABSOLUTE MAXIMUM RATINGS $T_C = 25^\circ C$ unless otherwise noted

Parameter	Symbol	Limit	Units
Collector-to-Emitter Breakdown Voltage	V_{CES}	650	V
Gate-to-Emitter Voltage	V_{GE}	± 30	V
Continuous Collector Current @ $T_C = 25^\circ C$ @ $T_C = 100^\circ C$	I_C	14	A
		7	A
Pulsed Collector Current ,tp limited by Tjmax	I_{CM}	21	A
Diode Continuous Forward Current @ $T_C = 25^\circ C$ @ $T_C = 100^\circ C$	I_F	14	A
		7	A
Diode Maximum Forward Current	I_{FM}	21	A
Maximum Power Dissipation @ $T_C = 25^\circ C$ @ $T_C = 100^\circ C$	P_D	69	W
		28	W
Operating Junction Temperature	T_J	-40 to 150	$^\circ C$
Storage Temperature Range	T_{STG}	-55 to 150	$^\circ C$

Thermal Characteristics

Parameter	Symbol	Limit	Units
Thermal Resistance, Junction-to-Case for IGBT	$R_{\theta JC}$	1.8	$^\circ C/W$
Thermal Resistance, Junction-to-Ambient	$R_{\theta JA}$	62	$^\circ C/W$

Electrical Characteristics $T_C = 25^\circ\text{C}$ unless otherwise noted

Parameter	Symbol	Test Condition	Min	Typ	Max	Units	
Collector-Emitter Breakdown Voltage	BV_{CES}	$V_{GE} = 0V, I_C = 1mA$	650			V	
Zero Gate Voltage Collector Current	I_{CES}	$V_{CE} = 650V, V_{GE} = 0V$			1	μA	
Gate Body Leakage Current, Forward	I_{GESF}	$V_{GE} = 30V, V_{CE} = 0V$			200	nA	
Gate Body Leakage Current, Reverse	I_{GESR}	$V_{GE} = -30V, V_{CE} = 0V$			-200	nA	
Gate Threshold Voltage	$V_{GE(th)}$	$V_{GE} = V_{CE}, I_C = 1mA$	4.5		6.5	V	
Collector-Emitter saturation Voltage	$V_{CE(sat)}$	$V_{GE} = 15V, I_C = 7A$		1.55	2	V	
Input Capacitance	C_{ies}	$V_{CE} = 25V, V_{GE} = 0V,$ $f = 1MHz$		410		pF	
Output Capacitance	C_{oes}			25		pF	
Reverse Transfer Capacitance	C_{res}			5		pF	
Turn-On Delay Time	$t_{d(on)}$	$V_{CC} = 400V, I_C = 7A,$ $V_{GE} = 15V, R_{GEN} = 5\Omega$ Inductive Load $T_a = 25^\circ\text{C}$		20		ns	
Turn-On Rise Time	t_r			16		ns	
Turn-Off Delay Time	$t_{d(off)}$			40		ns	
Turn-Off Fall Time	t_f			82		ns	
Turn-On Switching Loss	E_{on}				0.017		mJ
Turn-Off Switching Loss	E_{off}				0.017		mJ
Total Gate Charge	Q_g		$V_{CC} = 480V, I_C = 7A,$ $V_{GE} = 15V$		15		nC
Gate-Emitter Charge	Q_{ge}				3		nC
Gate-Collector Charge	Q_{gc}			7.5		nC	

Electrical Characteristics of Diode $T_C = 25^\circ\text{C}$ unless otherwise noted

Parameter	Symbol	Test Condition	Min	Typ	Max	Units
Diode Forward Voltage	V_F	$I_F = 7A$		1.5	2	V
Diode Reverse Recovery Time	t_{rr}	$I_F = 7A$ $di_F / dt = 100A / \mu s$		45		ns
Diode peak Reverse Recovery Current	I_{rr}			7.3		A
Diode Reverse Recovery Charge	Q_{rr}			0.24		μC

Notes :Pulse width $\leq 300\mu s$, Duty Cycle $\leq 2\%$.

TYPICAL PERFORMANCE CHARACTERISTICS

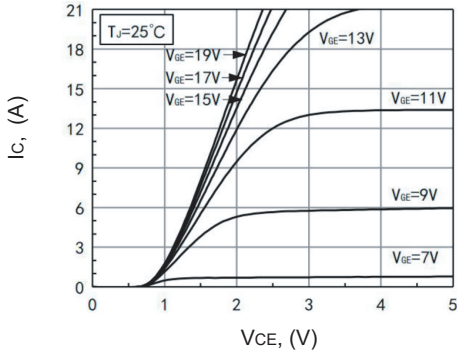

Figure 1. Output Characteristics

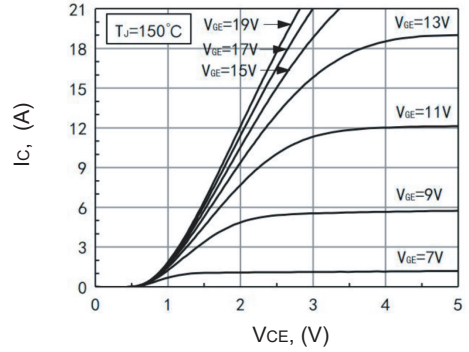

Figure 2. Output Characteristics

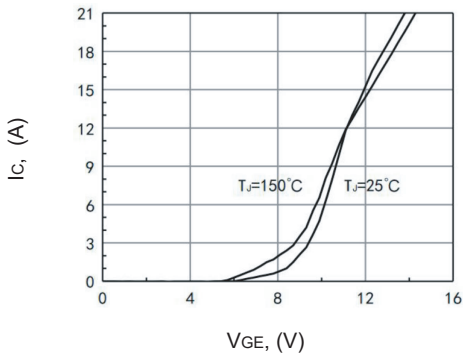

Figure 3. Typical Transfer Characteristics

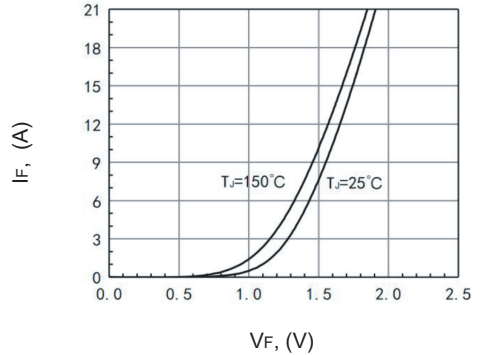

Figure 4. Diode forward current vs forward voltage

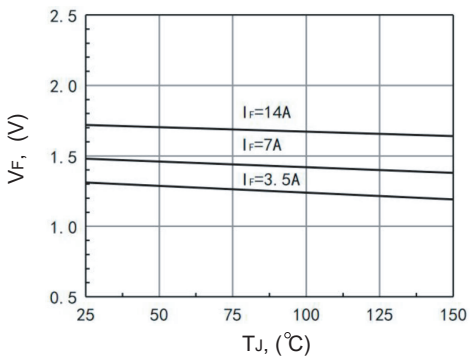

Figure 5. Forward Voltage vs Junction Temperature

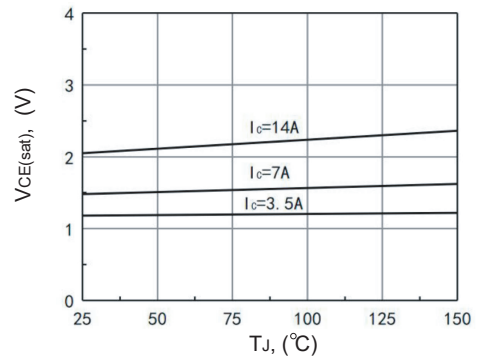

Figure 6. Typical $V_{CE(sat)}$ vs T_J Characteristics

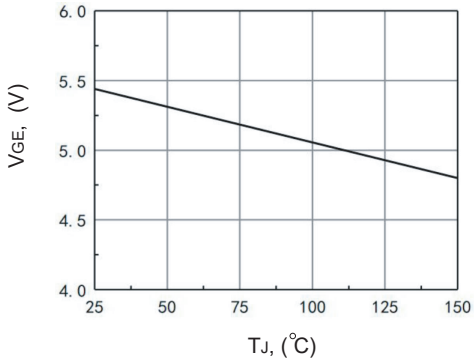

Figure 7. $V_{GE(th)}$ vs T_J Characteristics

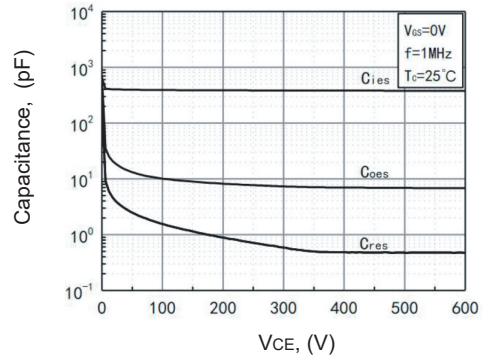

Figure 8. Capacitance Characteristics

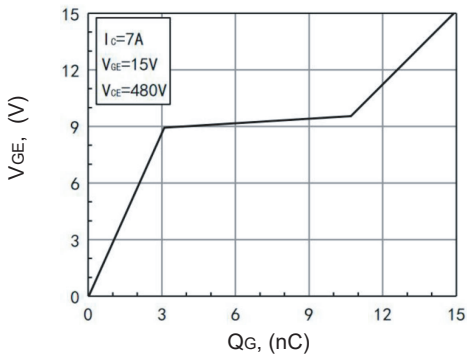

Figure 9. Gate Charge Wave Form

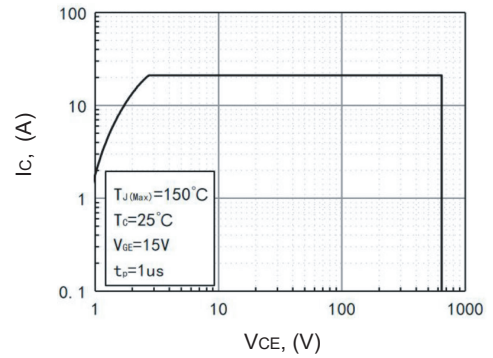

Figure 10. Forward Bias Safe Operating Area

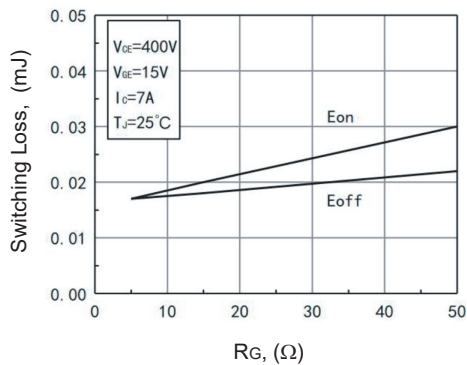

Figure 11. Switching Loss vs Gate Resistances

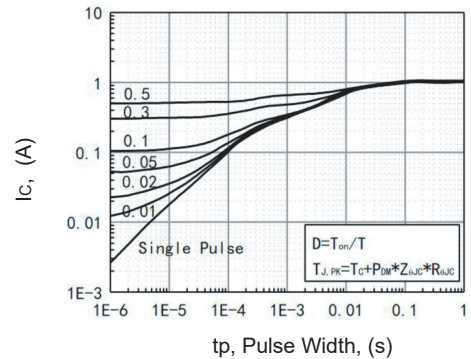
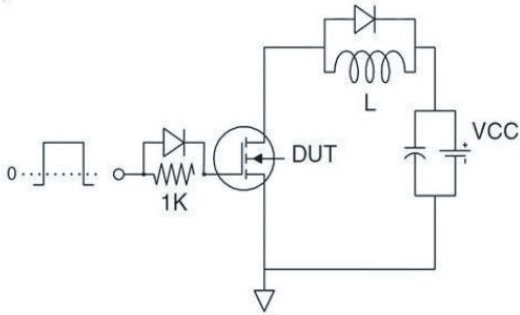
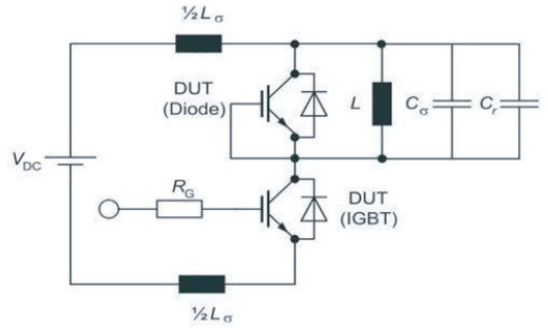

Figure 12. Transient Thermal Resistances

TEST CIRCUIT



Gate Charge Test Circuit



Switch Time Test Circuit

SWITCHING CHARACTERISTICS

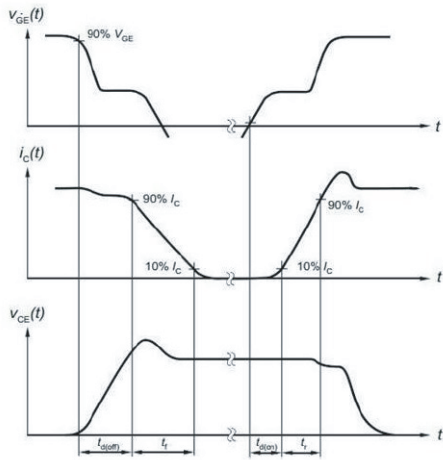

Definition of switching times

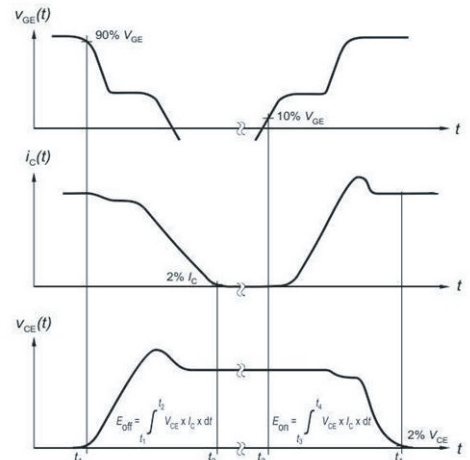

Definition of switching losses

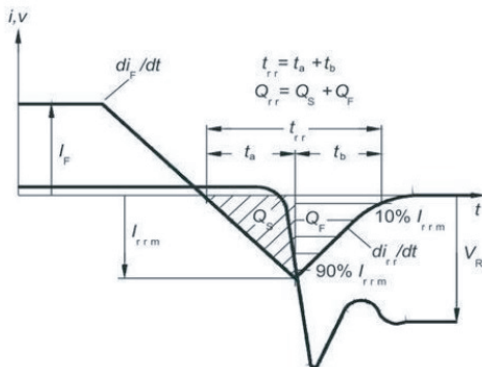

Definition of diode switching characteristics