

# 華瑞功率電子股份有限公司

## CET-MOS Corporation

### 1. TO-3P 產品外觀尺寸圖 (Product Outline Dimension)

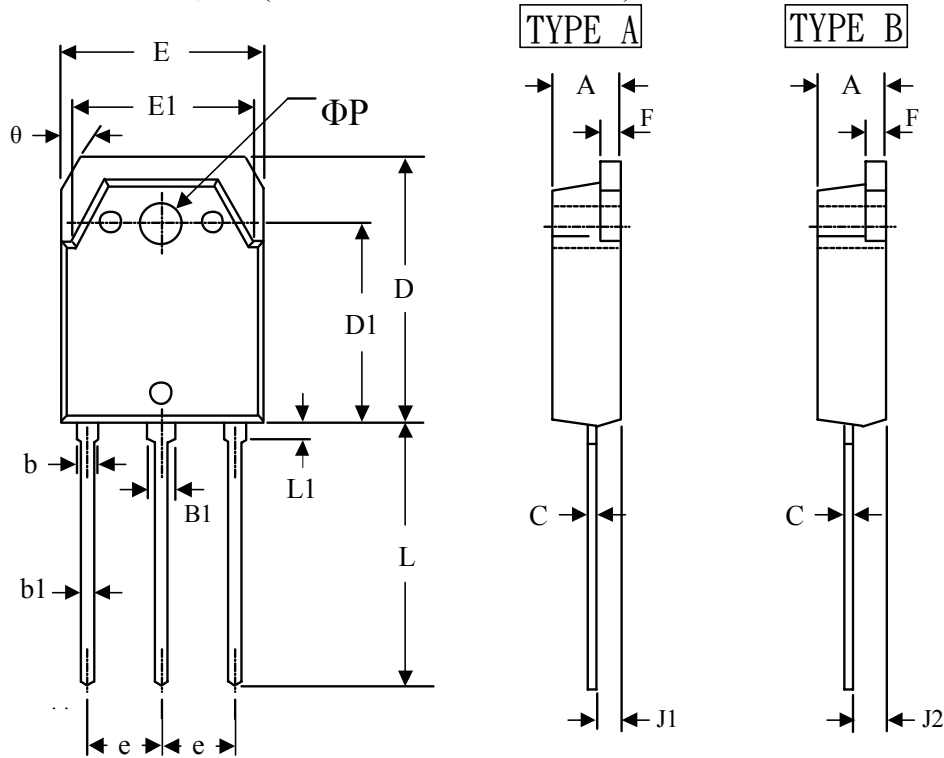

SYMBOLS	MILLIMETERS		INCHES	
	MIN	MAX	MIN	MAX
A	4.500	5.100	0.177	0.201
B1	2.800	3.200	0.110	0.126
b	1.800	2.200	0.070	0.087
b1	0.800	1.200	0.031	0.047
C	0.500	0.700	0.020	0.028
D	19.200	20.300	0.756	0.799
D1	14.200	15.200	0.560	0.598
E	15.400	15.800	0.606	0.622
E1	13.400	13.800	0.528	0.543
e	5.45BSC		0.215BSC	
F	1.400	1.800	0.055	0.071
J1	1.200	1.600	0.047	0.063
J2	2.200	2.600	0.087	0.102
L	19.800	21.000	0.780	0.827
L1	3.100	3.850	0.122	0.152
$\Phi P$	3.200	3.500	0.118	0.134
$\theta$	0°	30°	0°	30°

TITLE	SH	OF	SPEC. NO.	REV.
-------	----	----	-----------	------