

## P-Channel Enhancement Mode Field Effect Transistor

### FEATURES

Type	V <sub>DSS</sub>	R <sub>DS(ON)</sub>	I <sub>D</sub>	@V <sub>GS</sub>
CEP15P15A	-150V	190mΩ	-15A	-10V
CEB15P15A	-150V	190mΩ	-15A	-10V
CEF15P15A	-150V	190mΩ	-15A <sup>d</sup>	-10V

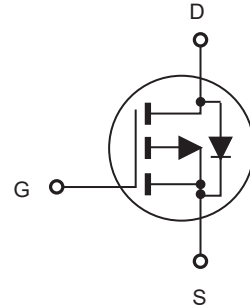

- Super high dense cell design for extremely low R<sub>DS(ON)</sub>.
- High power and current handling capability.
- Pb-free lead plating ; RoHS compliant.
- Halogen Free.

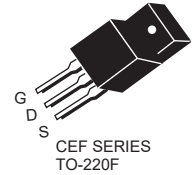

### ABSOLUTE MAXIMUM RATINGS $T_C = 25^\circ\text{C}$ unless otherwise noted

Parameter	Symbol	Limit		Units
		TO-220/263	TO-220F	
Drain-Source Voltage	V <sub>DS</sub>	-150		V
Gate-Source Voltage	V <sub>GS</sub>	± 20		V
Drain Current-Continuous @ T <sub>C</sub> = 25°C @ T <sub>C</sub> = 100°C	I <sub>D</sub>	-15	-15 <sup>d</sup>	A
		-9	-9 <sup>d</sup>	A
Drain Current-Pulsed <sup>a</sup>	I <sub>DM</sub> <sup>e</sup>	-60	-60 <sup>d</sup>	A
Maximum Power Dissipation @ T <sub>C</sub> = 25°C - Derate above 25°C	P <sub>D</sub>	76	34	W
		0.6	0.27	W/°C
Single Pulsed Avalanche Energy <sup>g</sup>	E <sub>AS</sub>	148		mJ
Single Pulsed Avalanche Current <sup>g</sup>	I <sub>AS</sub>	7.7		A
Operating and Store Temperature Range	T <sub>J</sub> , T <sub>stg</sub>	-55 to 150		°C

### Thermal Characteristics

Parameter	Symbol	Limit		Units
Thermal Resistance, Junction-to-Case	R <sub>θJC</sub>	1.64	3.7	°C/W
Thermal Resistance, Junction-to-Ambient	R <sub>θJA</sub>	62.5	65	°C/W



# CEP15P15A/CEB15P15A CEF15P15A

## Electrical Characteristics $T_C = 25^\circ\text{C}$ unless otherwise noted

Parameter	Symbol	Test Condition	Min	Typ	Max	Units
<b>Off Characteristics</b>						
Drain-Source Breakdown Voltage	$BV_{DSS}$	$V_{GS} = 0V, I_D = -250\mu A$	-150			V
Zero Gate Voltage Drain Current	$I_{DSS}$	$V_{DS} = -150V, V_{GS} = 0V$			-1	$\mu A$
Gate Body Leakage Current, Forward	$I_{GSSF}$	$V_{GS} = 20V, V_{DS} = 0V$			100	nA
Gate Body Leakage Current, Reverse	$I_{GSSR}$	$V_{GS} = -20V, V_{DS} = 0V$			-100	nA
<b>On Characteristics<sup>b</sup></b>						
Gate Threshold Voltage	$V_{GS(th)}$	$V_{GS} = V_{DS}, I_D = -250\mu A$	-2		-4	V
Static Drain-Source On-Resistance	$R_{DS(on)}$	$V_{GS} = -10V, I_D = -7.5A$		153	190	$m\Omega$
Gate Input Resistance	$R_g$	$f=1\text{MHz, open Drain}$		3.7		$\Omega$
<b>Dynamic Characteristics<sup>c</sup></b>						
Input Capacitance	$C_{iss}$	$V_{DS} = -25V, V_{GS} = 0V,$ $f = 1.0 \text{ MHz}$		2340		pF
Output Capacitance	$C_{oss}$			125		pF
Reverse Transfer Capacitance	$C_{rss}$			95		pF
<b>Switching Characteristics<sup>c</sup></b>						
Turn-On Delay Time	$t_{d(on)}$	$V_{DD} = -75V, I_D = -7.5A,$ $V_{GS} = -10V, R_{GEN} = 10\Omega$		22		ns
Turn-On Rise Time	$t_r$			14		ns
Turn-Off Delay Time	$t_{d(off)}$			66		ns
Turn-Off Fall Time	$t_f$			22		ns
Total Gate Charge	$Q_g$	$V_{DS} = -120V, I_D = -7.5A,$ $V_{GS} = -10V$		45		nC
Gate-Source Charge	$Q_{gs}$			8		nC
Gate-Drain Charge	$Q_{gd}$			15		nC
<b>Drain-Source Diode Characteristics and Maximum Ratings</b>						
Drain-Source Diode Forward Current	$I_S^f$				-15	A
Drain-Source Diode Forward Voltage <sup>b</sup>	$V_{SD}$	$V_{GS} = 0V, I_S = -15A$			-1.3	V
<b>Notes :</b> a.Repetitive Rating : Pulse width limited by maximum junction temperature . b.Pulse Test : Pulse Width $\leq 300\mu s$ , Duty Cycle $\leq 2\%$ . c.Guaranteed by design, not subject to production testing. d.Limited only by maximum temperature allowed . e.Pulse width limited by safe operating area . f.Full package $I_{S(max)} = 10A$ . g.L = 5mH, $I_{AS} = 7.7A$ , $V_{DD} = 50V$ , $R_G = 25\Omega$ , Starting $T_J = 25^\circ\text{C}$ .						



# CEP15P15A/CEB15P15A CEF15P15A

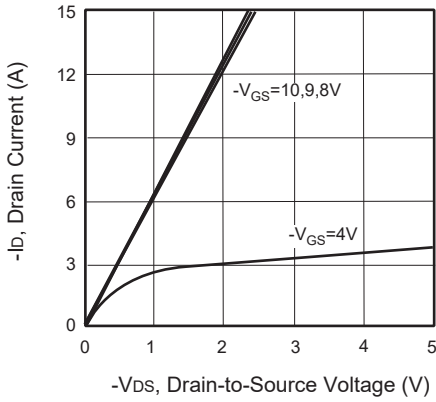

Figure 1. Output Characteristics

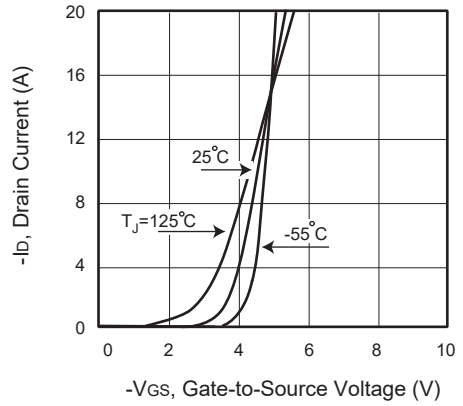

Figure 2. Transfer Characteristics

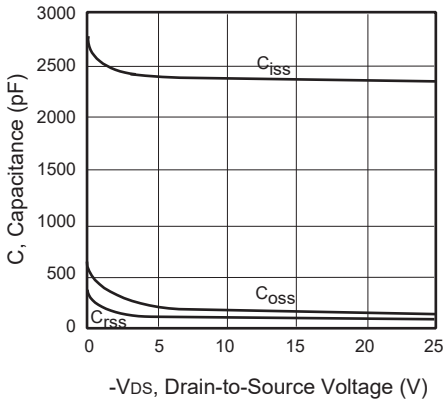

Figure 3. Capacitance

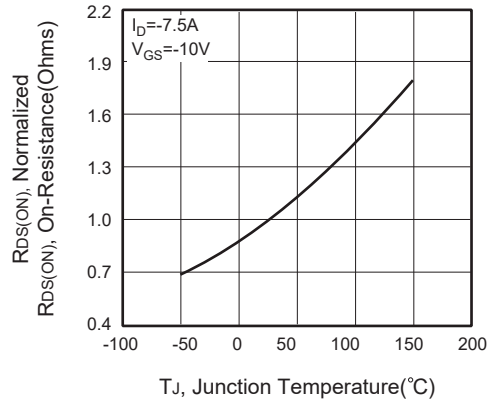

Figure 4. On-Resistance Variation with Temperature

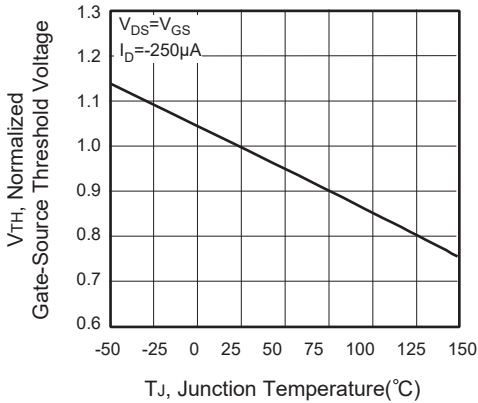

Figure 5. Gate Threshold Variation with Temperature

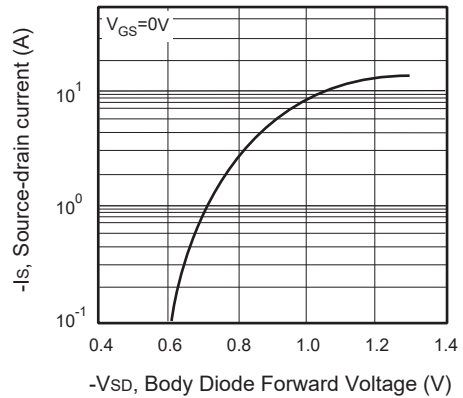
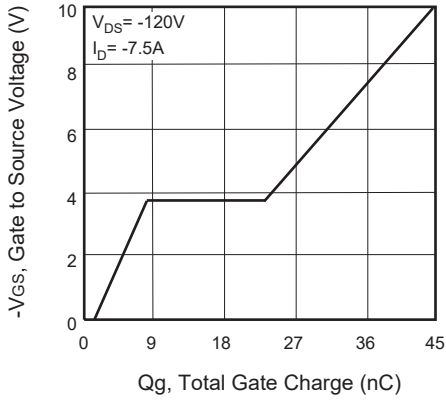
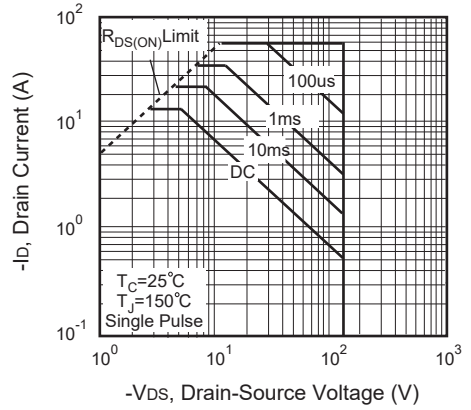

Figure 6. Body Diode Forward Voltage Variation with Source Current



**Figure 7. Gate Charge**



**Figure 8. Maximum Safe Operating Area**

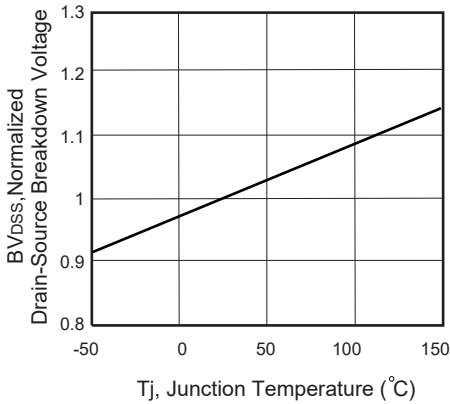

**Figure 9. Breakdown Voltage Variation VS Temperature**

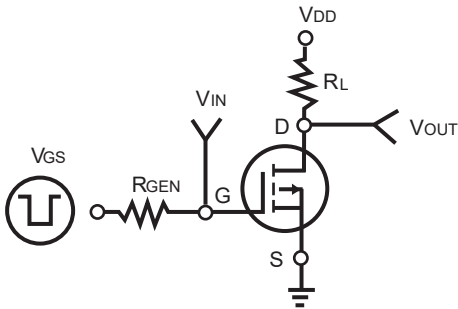

**Figure 10. Switching Test Circuit**

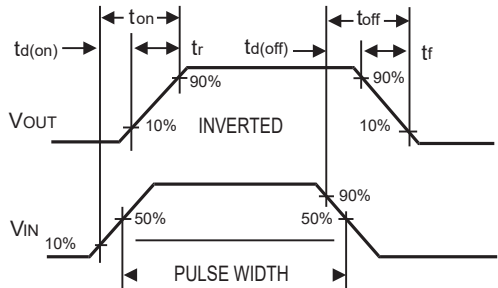

**Figure 11. Switching Waveforms**



# CEP15P15A/CEB15P15A CEF15P15A

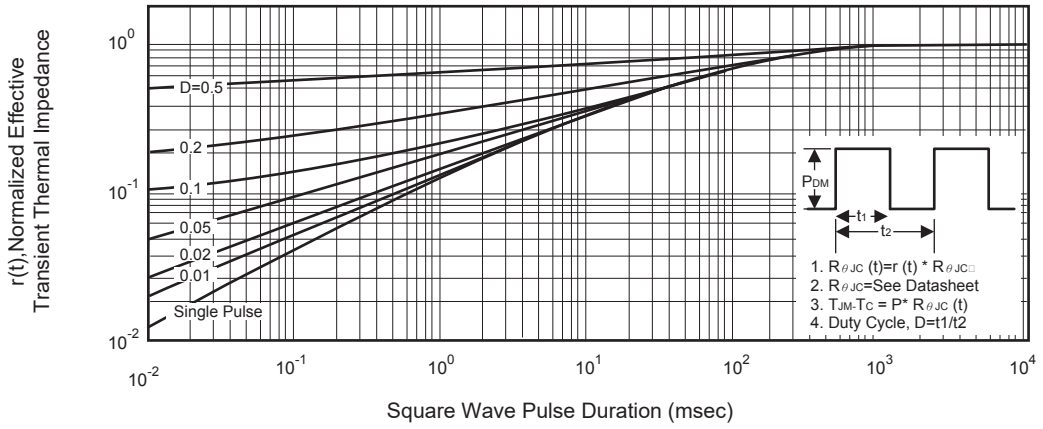

Figure 12. Normalized Thermal Transient Impedance Curve