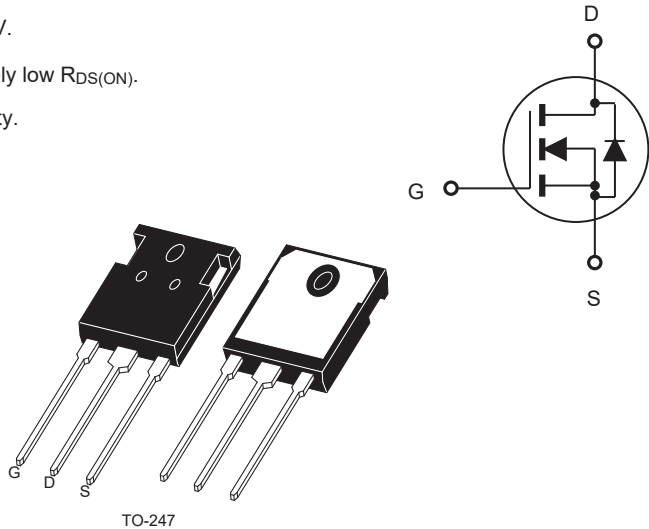


## N-Channel Enhancement Mode Field Effect Transistor

### FEATURES

- 1500V, 5A,  $R_{DS(ON)} = 4.5\Omega$  @  $V_{GS} = 10V$ .
- Super high dense cell design for extremely low  $R_{DS(ON)}$ .
- High power and current handling capability.
- Pb-free lead plating ; RoHS compliant.
- Halogen Free.
- TO-247 package.



### ABSOLUTE MAXIMUM RATINGS $T_C = 25^\circ\text{C}$ unless otherwise noted

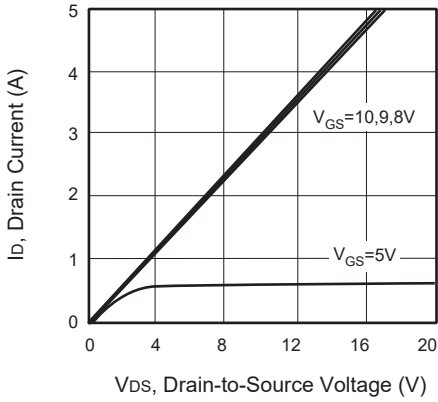
Parameter	Symbol	Limit	Units
Drain-Source Voltage	$V_{DS}$	1500	V
Gate-Source Voltage	$V_{GS}$	$\pm 30$	V
Drain Current-Continuous @ $T_C = 25^\circ\text{C}$ @ $T_C = 100^\circ\text{C}$	$I_D$	5 3	A A
Drain Current-Pulsed <sup>a</sup>	$I_{DM}$	20	A
Maximum Power Dissipation @ $T_C = 25^\circ\text{C}$ - Derate above $25^\circ\text{C}$	$P_D$	278 2.22	W W/ $^\circ\text{C}$
Single Pulsed Avalanche Energy <sup>d</sup>	$E_{AS}$	550	mJ
Single Pulsed Avalanche Current <sup>d</sup>	$I_{AS}$	5	A
Operating and Store Temperature Range	$T_J, T_{stg}$	-55 to 150	$^\circ\text{C}$

### Thermal Characteristics

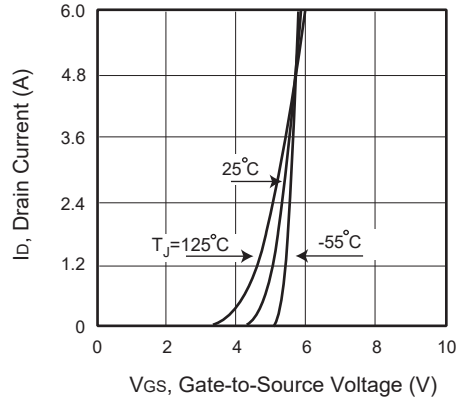
Parameter	Symbol	Limit	Units
Thermal Resistance, Junction-to-Case	$R_{\theta JC}$	0.45	$^\circ\text{C/W}$
Thermal Resistance, Junction-to-Ambient	$R_{\theta JA}$	62.5	$^\circ\text{C/W}$

## Electrical Characteristics $T_C = 25^\circ\text{C}$ unless otherwise noted

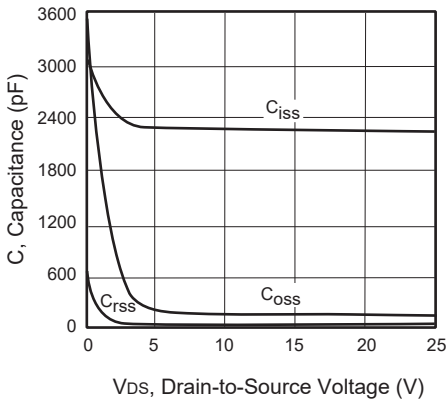
Parameter	Symbol	Test Condition	Min	Typ	Max	Units
<b>Off Characteristics</b>						
Drain-Source Breakdown Voltage	$BV_{DSS}$	$V_{GS} = 0V, I_D = 250\mu A$	1500			V
Zero Gate Voltage Drain Current	$I_{DSS}$	$V_{DS} = 1500V, V_{GS} = 0V$			10	$\mu A$
Gate Body Leakage Current, Forward	$I_{GSSF}$	$V_{GS} = 30V, V_{DS} = 0V$			100	nA
Gate Body Leakage Current, Reverse	$I_{GSSR}$	$V_{GS} = -30V, V_{DS} = 0V$			-100	nA
<b>On Characteristics<sup>b</sup></b>						
Gate Threshold Voltage	$V_{GS(th)}$	$V_{GS} = V_{DS}, I_D = 250\mu A$	3		5	V
Static Drain-Source On-Resistance	$R_{DS(on)}$	$V_{GS} = 10V, I_D = 2A$		3.5	4.5	$\Omega$
Gate Input Resistance	$R_g$	$f=1\text{MHz}, \text{open Drain}$		1.9		$\Omega$
<b>Dynamic Characteristics<sup>c</sup></b>						
Input Capacitance	$C_{iss}$	$V_{DS} = 25V, V_{GS} = 0V,$ $f = 1\text{MHz}$		2225		pF
Output Capacitance	$C_{oss}$			150		pF
Reverse Transfer Capacitance	$C_{rss}$			10		pF
<b>Switching Characteristics<sup>c</sup></b>						
Turn-On Delay Time	$t_{d(on)}$	$V_{DD} = 750V, I_D = 2A,$ $V_{GS} = 10V, R_{GEN} = 5\Omega$		34		ns
Turn-On Rise Time	$t_r$			19		ns
Turn-Off Delay Time	$t_{d(off)}$			61		ns
Turn-Off Fall Time	$t_f$			28		ns
Total Gate Charge	$Q_g$	$V_{DS} = 750V, I_D = 2A,$ $V_{GS} = 10V$		46		nC
Gate-Source Charge	$Q_{gs}$			10		nC
Gate-Drain Charge	$Q_{gd}$			20		nC
<b>Drain-Source Diode Characteristics and Maximum Ratings</b>						
Drain-Source Diode Forward Current	$I_S$				5	A
Drain-Source Diode Forward Voltage <sup>b</sup>	$V_{SD}$	$V_{GS} = 0V, I_S = 2A$			1.4	V
Reverse Recovery Time	$T_{rr}$	$I_F = 5A, di/dt = 100A/\mu s$		600		ns
Reverse Recovery Charge	$Q_{rr}$				1.2	
<b>Notes :</b> a. Repetitive Rating : Pulse width limited by maximum junction temperature. b. Pulse Test : Pulse Width $\leq 300\mu s$ , Duty Cycle $\leq 2\%$ . c. Guaranteed by design, not subject to production testing. d. $L = 44\text{mH}, I_S = 5A, V_{DD} = 90V, R_G = 25\Omega$ , Starting $T_J = 25^\circ\text{C}$ .						



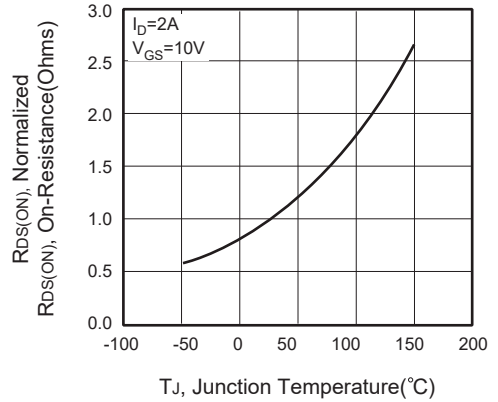
**Figure 1. Output Characteristics**



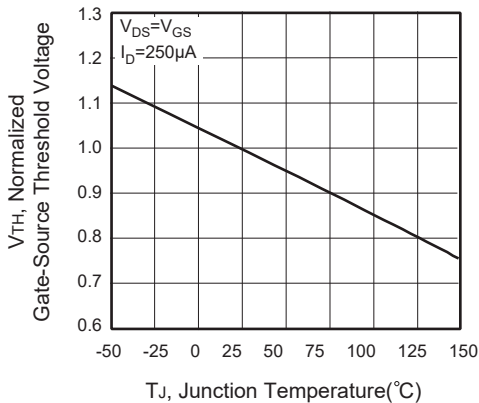
**Figure 2. Transfer Characteristics**



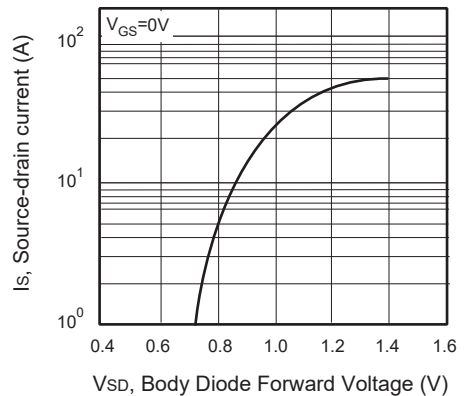
**Figure 3. Capacitance**



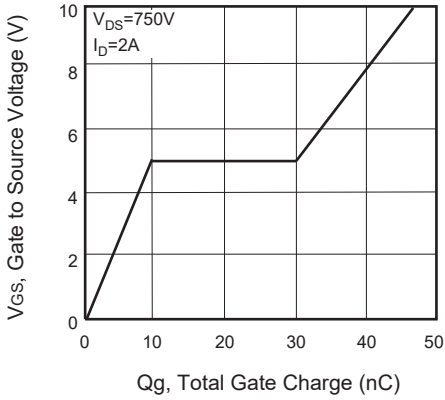
**Figure 4. On-Resistance Variation with Temperature**



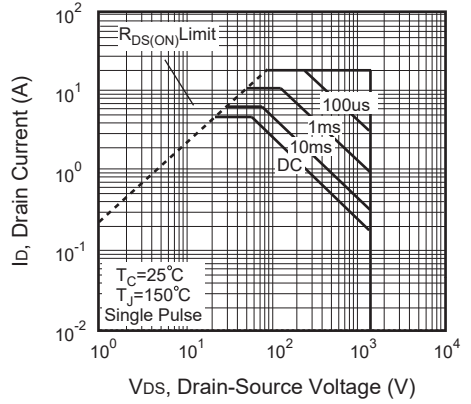
**Figure 5. Gate Threshold Variation with Temperature**



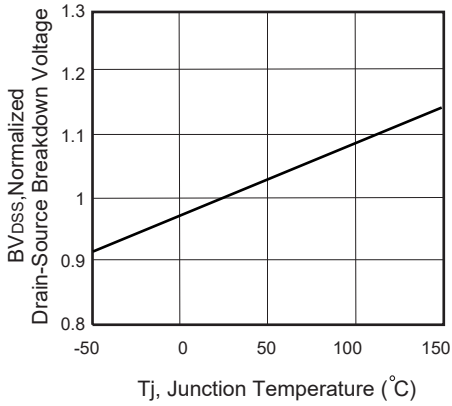
**Figure 6. Body Diode Forward Voltage Variation with Source Current**



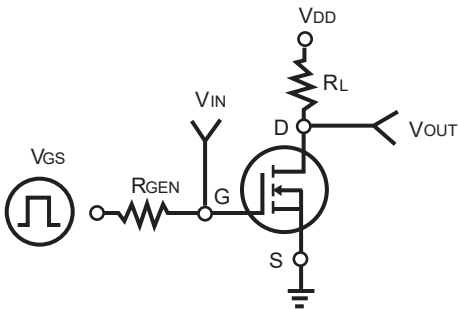
**Figure 7. Gate Charge**



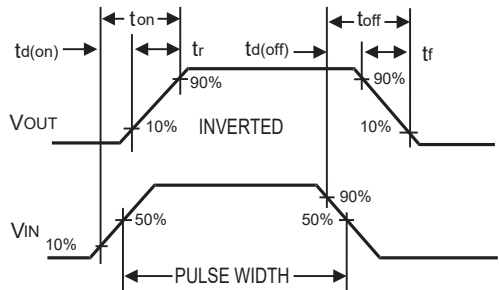
**Figure 8. Maximum Safe Operating Area**



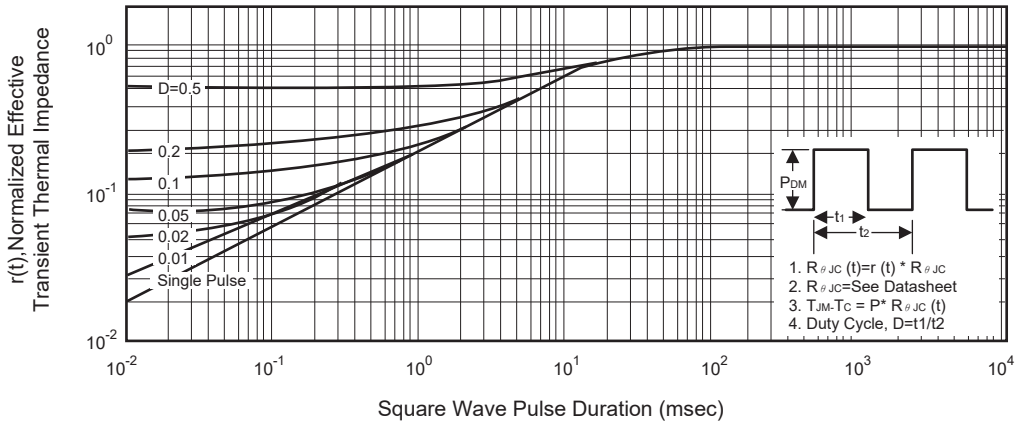
**Figure 9. Breakdown Voltage Variation VS Temperature**



**Figure 10. Switching Test Circuit**

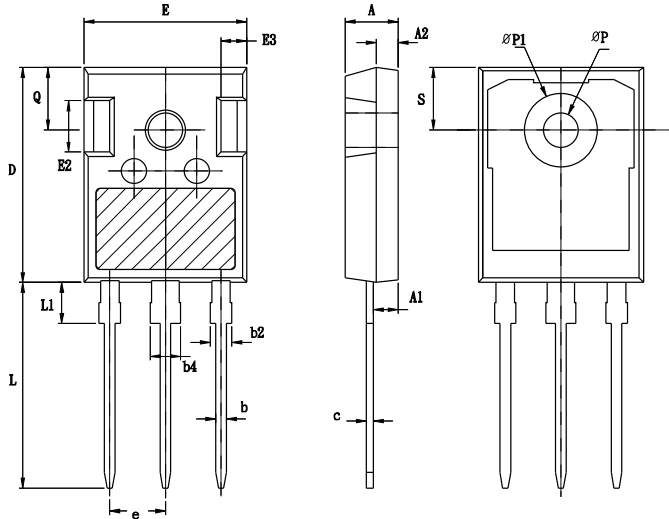


**Figure 11. Switching Waveforms**



**Figure 12. Normalized Thermal Transient Impedance Curve**

## TO-247 產品外觀尺寸圖 (Product Outline Dimension)



SYMBOLS	MILLIMETERS		INCHES	
	MIN	MAX	MIN	MAX
A	4.830	5.210	0.190	0.205
A1	2.310	2.510	0.091	0.099
A2	1.900	2.160	0.075	0.085
b	1.140	1.400	0.045	0.055
b2	1.910	2.200	0.075	0.087
b4	2.960	3.160	0.117	0.124
C	0.550	0.750	0.022	0.030
D	20.800	21.340	0.819	0.840
e	5.45BSC		0.215BSC	
E	15.700	16.130	0.618	0.635
E2	4.320	5.100	0.170	0.201
E3	1.58	2.60	0.062	0.102
L	19.80	20.57	0.780	0.810
L1	3.81	4.32	0.150	0.170
ΦP	3.5	3.7	0.138	0.146
ΦP1	~	7.3	~	0.287
S	6.15BSC		0.242BSC	
Q	5.59	6.2	0.220	0.244